

SERVICE PARTS INFORMATION  
 FOR  
 COMMERCIAL DOOR OPERATOR  
 MODEL SBD - 03  
 SIDE MOUNT VERTICAL LIFT

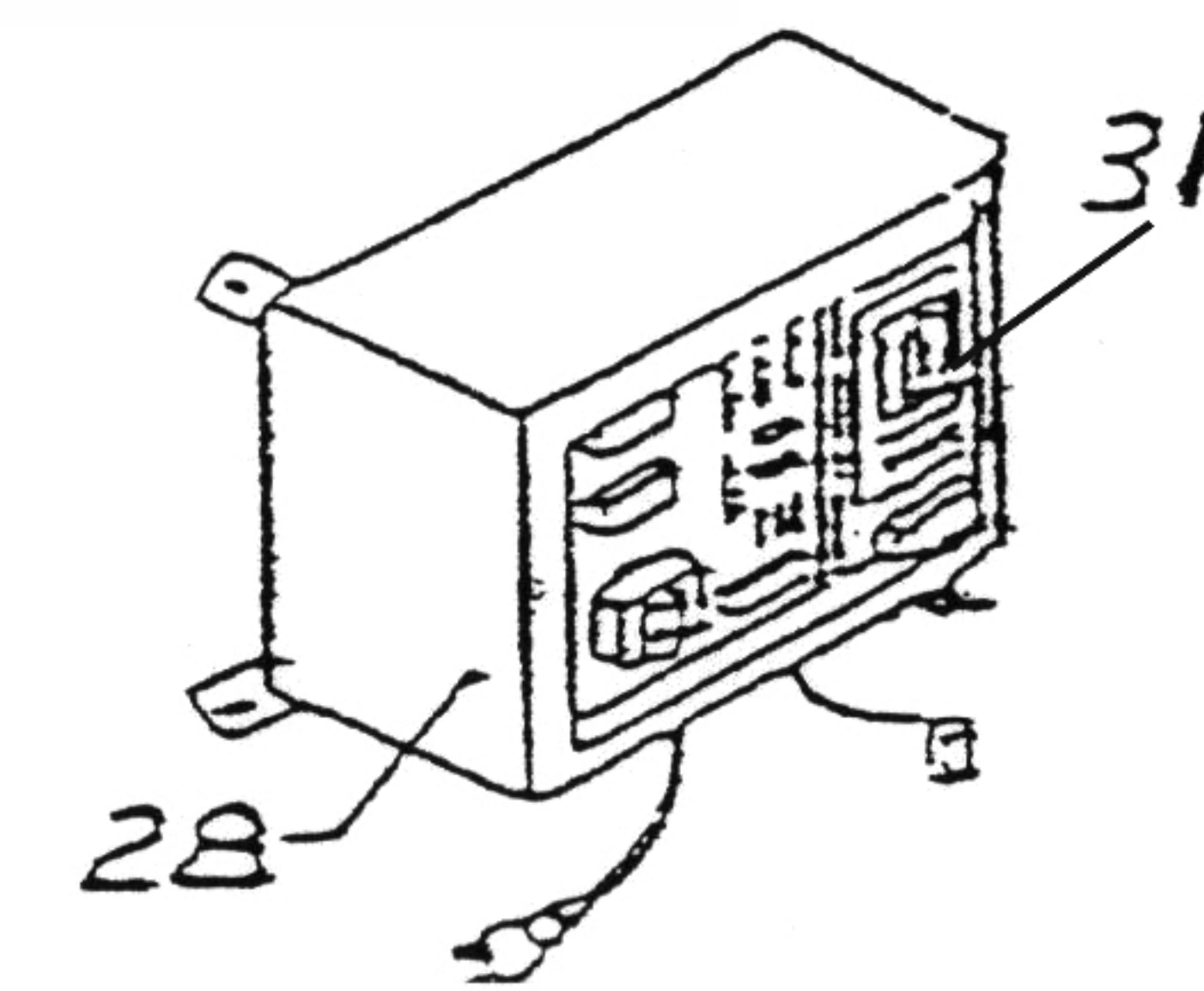

PART NO.	DESCRIPTION	NO OFF
43	WASHER	2
42	BELT H100 PER METRE	1
41	END BRACKET CLAMP	1
40B	END BRACKET	1
39	SPACER	1
38	DRIVE UNIT COVER	1
37	GEAR BOX SPACER	1
36	PC BOARD ONLY	1
35B	BASE PLATE BRACKET	1
33	PEDISTRAIN P/B SWITCH	1
32	PULL CORD SWITCH	1
31	RECEIVER	1
30	IDLER BEARING	2
29	TRANSMITTER	1
28	CONTROL MODULE	1
27	IDLER PULLEY	1
26	IDLER PULLEY SHAFT	1
24B	DOOR BRACKET	1
23	RELEASE ARM	1
22	TROLLEY	1
21	BELT JOINER	2
20	GUIDE BLOCK	2
19	ADJUSTER BLOCK	1
18	LINK SHAFT	1
17	DRIVE BEARING	2
16	DRIVE CHANNEL COVER	1
15	DRIVE CHANNEL	1
14	BASE PLATE	1
13	REED SWITCH	2
12	ADJUSTER	1
11	REED SWITCH CHANNEL	1
10	FLANGE	2
9	DRIVE PULLEY H100	1
8	KEY 6 x 6	2
7	DRIVE SHAFT	1
6	GEAR BOX	1
2	MOTOR BRACKET	2
1	MOTOR 240v 50hz 3a 900rpm	1

**MANUAL OVERRIDE**  
 SLIDE EYEBOLT IN DIRECTION  
 OF ARROW AND RELEASE  
 PUSHARM FROM TROLLEY

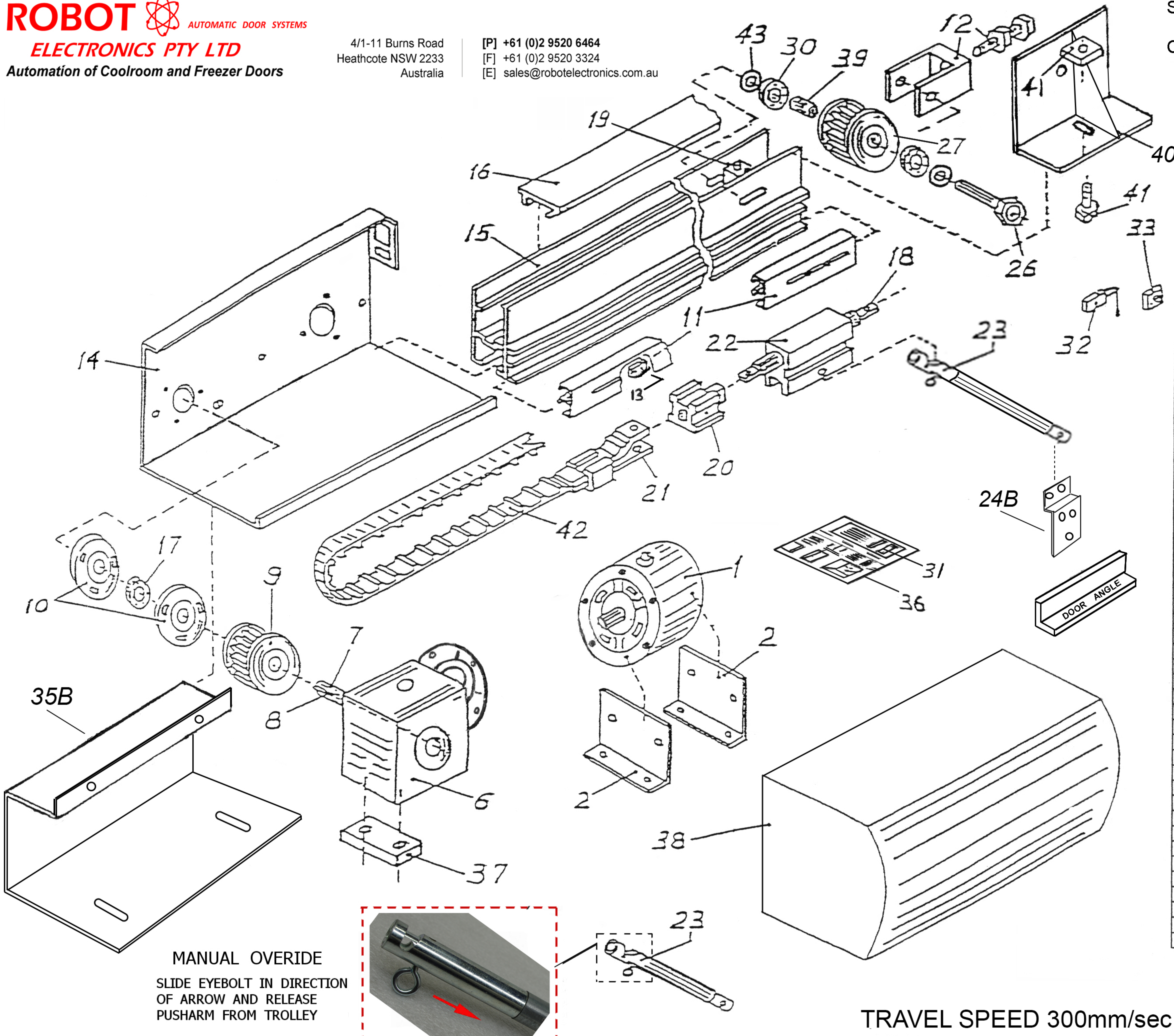
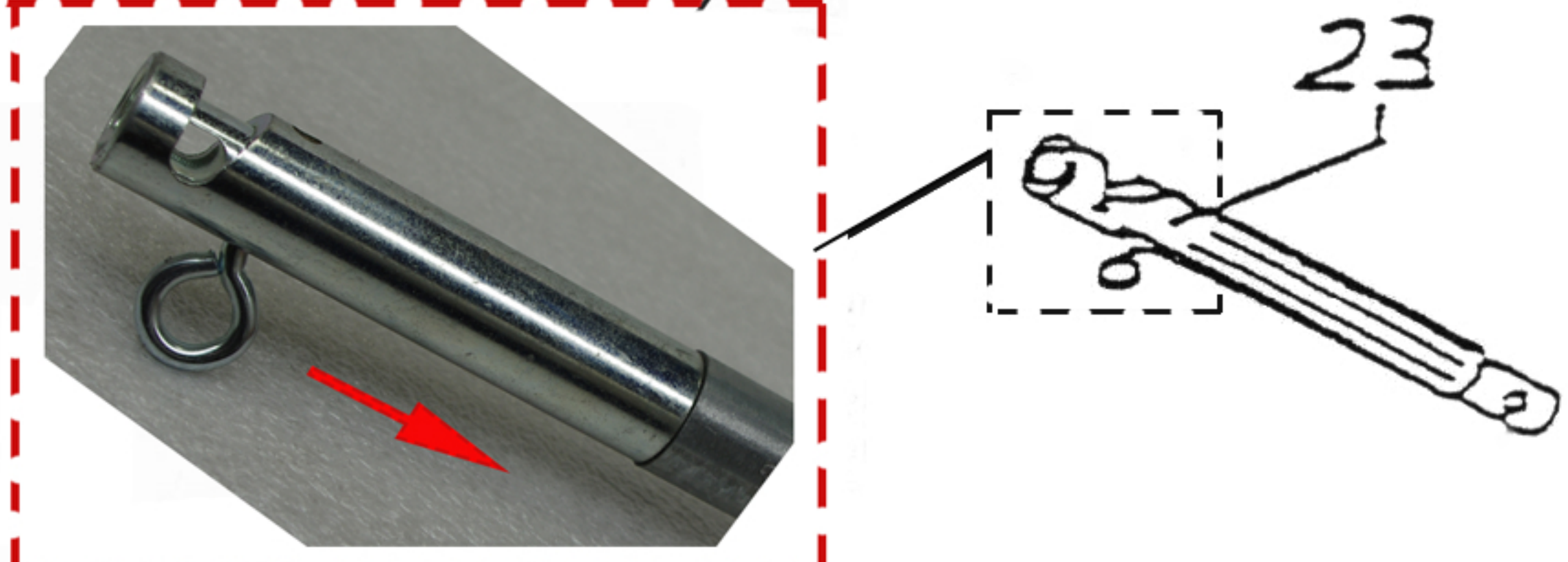

**TRAVEL SPEED 300mm/sec**